

HDD Mud Pump PSE 70-210 C

Compact high-capacity pump for drilling fluids operating at pressures up to 150 bar.

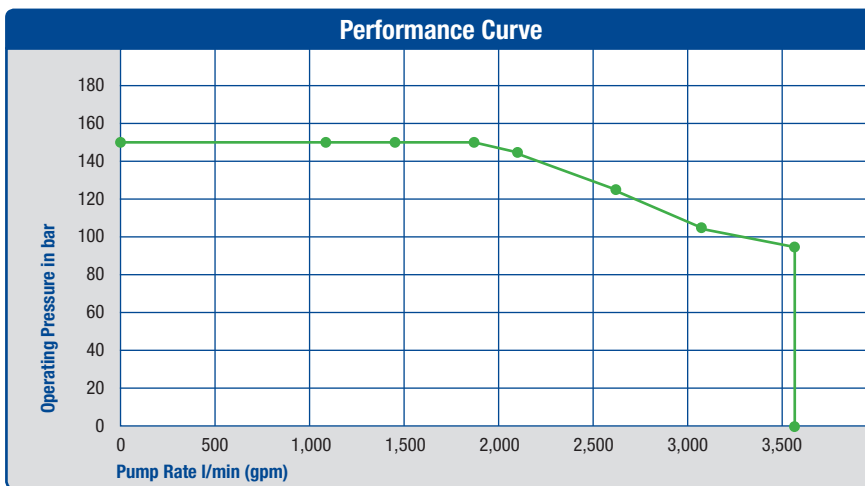
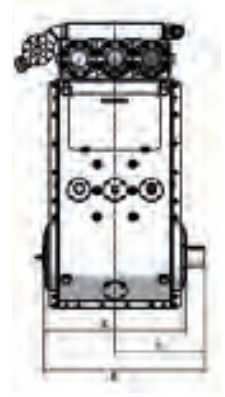
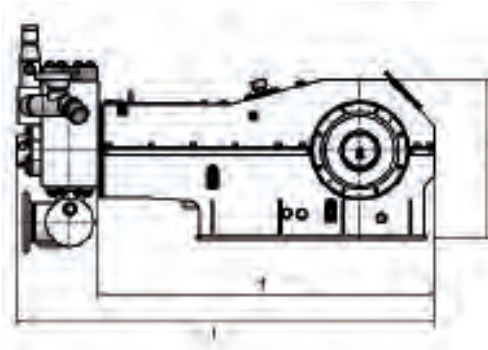
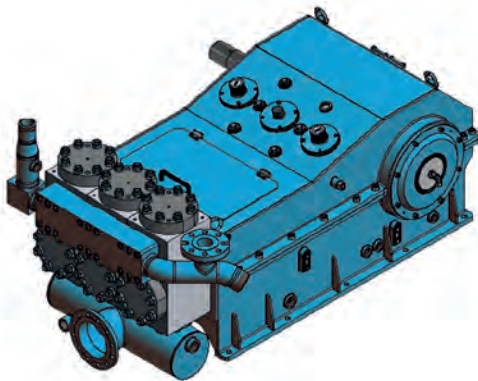

Dimensions

L Total Length	2,364 mm
F Length only power end	1,905 mm
H Total Height	1,284 mm
B Total Width	1,544 mm
g Width excluding journal	1,178 mm
e Width from center line	748 mm

Piston-Ø	Inch	4	4.5	5	5.5	6	6.5	7
	mm	101.6	114.3	127	139.7	152.4	165.1	177.8
Operat. Pressure	bar (psi)	150 (2,176)	150 (2,176)	150 (2,176)	146 (2,118)	123 (1,784)	105 (1,523)	90 (1,305)
Revolutions		Pumping Rate l/min (gpm)						
230 min ⁻¹		1,175 (310)	1,487 (393)	1,836 (485)	2,221 (587)	2,643 (698)	3,102 (819)	3,598 (950)
200 min ⁻¹		1,022 (270)	1,293 (342)	1,596 (422)	1,931 (510)	2,298 (607)	2,697 (712)	3,128 (826)
150 min ⁻¹		766 (202)	940 (256)	1,197 (316)	1,448 (383)	1,724 (455)	2,023 (534)	2,346 (620)
100 min ⁻¹		511 (135)	646 (171)	798 (211)	966 (255)	1,149 (304)	1,349 (356)	1,564 (413)
50 min ⁻¹		255 (67,4)	323 (85,3)	399 (105)	483 (128)	575 (152)	674 (178)	782 (207)

Data Performance

Weight	approx. 5,200 kg
Pumping Rate	up to 3,598 l/min
Drive Power	up to 575 kW
Fluids	Drilling Suspension, Bentonite Mixture
Fluid Temperature	up to 90 °C
Piston Force Max.	225,000 N
Stroke	210 mm
Average Piston Speed	230 min-1: 1.61 m/sec. 200 min-1: 1.40 m/sec. 150 min-1: 1.05 m/sec.