

HDD Mud Pump PSE 60-180

Compact high-capacity pump for drilling fluids operating at pressures up to 350 bar.

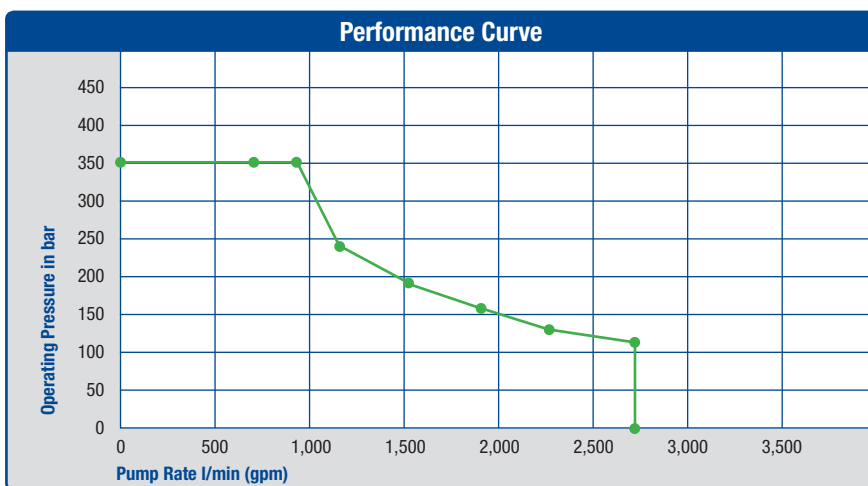
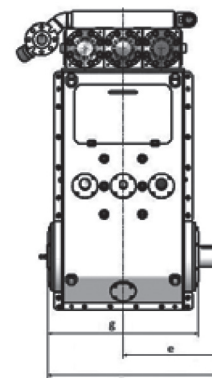
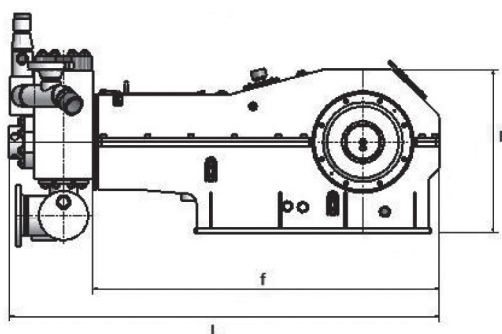
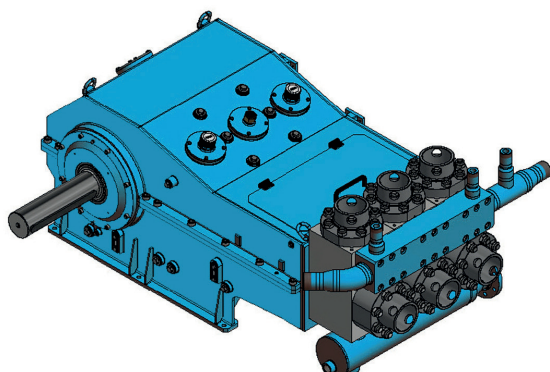

Dimensions

| | |
|---------------------------|----------|
| L Total Length | 2,280 mm |
| F Length only power end | 1,830 mm |
| H Total Height | 955 mm |
| B Total Width | 1,300 mm |
| g Width excluding journal | 1,020 mm |
| e Width from center line | 720 mm |

| Piston-Ø | Inch | 3 | 3.5 | 4 | 4.5 | 5 | 5.5 | 6 |
|-----------------------|-----------|---------------------------------|-------------|-------------|-------------|-------------|-------------|-------------|
| | mm | 76,2 | 88.9 | 101.6 | 114.3 | 127 | 139.7 | 152.4 |
| Operat. Pressure | bar (psi) | 350 (5,076) | 350 (5,076) | 245 (3,553) | 195 (2,828) | 155 (2,248) | 130 (1,886) | 110 (1,595) |
| Revolutions | | Pumping Rate l/min (gpm) | | | | | | |
| 275 min ⁻¹ | | 677 (179) | 922 (244) | 1,204 (318) | 1,524 (403) | 1,881 (497) | 2,276 (601) | 2,709 (716) |
| 250 min ⁻¹ | | 616 (163) | 838 (221) | 1,094 (289) | 1,385 (366) | 1,710 (452) | 2,069 (547) | 2,463 (651) |
| 200 min ⁻¹ | | 493 (130) | 670 (177) | 876 (231) | 1,108 (293) | 1,368 (361) | 1,655 (437) | 1,970 (520) |
| 150 min ⁻¹ | | 369 (97.5) | 503 (133) | 657 (174) | 831 (220) | 1,026 (271) | 1,242 (328) | 1,478 (390) |
| 100 min ⁻¹ | | 246 (62) | 335 (88.5) | 438 (116) | 554 (146) | 684 (181) | 828 (219) | 985 (260) |
| 50 min ⁻¹ | | 123 (32.5) | 168 (44.4) | 219 (57.9) | 277 (73.2) | 342 (90.3) | 414 (109) | 493 (130) |

Data Performance

| | |
|----------------------|--|
| Weight | approx. 4,950 kg |
| Pumping Rate | up to 2,709 l/min |
| Drive Power | up to 575 kW |
| Fluids | Drilling Suspension, Bentonite Mixture |
| Fluid Temperature | up to 90 °C |
| Piston Force Max. | 200,000 N |
| Stroke | 180 mm |
| Average Piston Speed | 275 min-1: 1.65 m/sec. 250 min-1: 1.50 m/sec. 200 min-1: 1.20 m/sec. |